

Spatial-Modulated Physical-Layer Network Coding in Two-Way Relay Networks with Convolutional Codes

Eunmi Chu
Chungnam National University
Daejeon, Korea, 34134
Email: emchu@cnu.ac.kr

Jae Sook Yoo
Chungnam National University
Daejeon, Korea, 34134
Email: mika15@naver.com

Bang Chul Jung
Chungnam National University
Daejeon, Korea, 34134
Email: bcjung@cnu.ac.kr

Abstract—We consider a spatial modulation (SM)-based physical-layer network coding (PNC) technique with convolutional codes (CC) for a two-way relay network (TWRN) consisting of two source nodes and a single relay node. We assume all communicating nodes are equipped with multiple antennas. Two source nodes simultaneously transmit packets by utilizing the SM with CC to the relay node. The relay node detects signal by utilizing a maximum-likelihood detection technique based on a direct decoding or a separate decoding algorithm. Through extensive simulations, it has been shown that the SM-based PNC technique outperforms the conventional PNC technique. Note that the direct decoding has low complexity, while achieving a similar performance to the separate decoding in terms of bit error rate (BER).

Keywords—Physical-layer network coding, spatial modulation, convolutional codes, two-way relay networks, multiple antennas

I. INTRODUCTION

A practical physical-layer network coding (PNC) technique has been received much interest by both academia and industry because it can significantly reduce feedback overhead and improve the spectral efficiency in the two-way relay network (TWRN) where two source nodes exchange their packets with each other via a relay node [1]. In the PNC in the TWRN, two source nodes simultaneously transmit their packets to the relay node while the relay node obtains the network-coded packet via an exclusive-OR (XOR) operation of two packets received from two source nodes. In particular, in [1], a maximal-likelihood detection (MLD) based on log-likelihood ratio (LLR) was adopted at the relay node for decoding the superposed signals from two sources, and both the PNC and channel coding were jointly considered. To *et al.* [2] proposed a combined architecture of convolutional codes (CCs) and the PNC and Yang *et al.* [3] investigated the decoding process of convolutional-coded PNC utilizing a joint channel-decoding algorithm. In [4], the bit error rate (BER) of the PNC with CCs was mathematically analyzed over fading channels and the optimal power allocation strategy was proposed to minimize the BER under sum power constraint at the source nodes.

Recently, a spatial modulation (SM) has been considered as a promising technique for next-generation mobile communication systems and SM technique has been applied to the TWRN with PNC [5]–[7]. In [5], the denoise-and-forward technique was adopted at the relay node, where the average symbol error probability was also analyzed. However, in [5], two source nodes with multiple antennas consider only the space shift

keying (SSK). The SSK modulation was also applied to the two-way amplify-and-forward (AF) relay network in [6]. In [7], a space-time coding technique was combined to the SM-based PNC technique by utilizing antenna selection at the relay node.

In this paper, we consider a SM-based PNC technique with CC in the TWRN where two source nodes and one relay node are equipped with multiple antennas. In the relay node, in particular, we consider two types of decoding methods: a *separate decoding* and a *direct decoding* [1]. The separate decoding individually decodes the packets from two source nodes, and then it performs network coding via XOR operation of the two decoded packets. In contrast, the direct decoding directly decodes a network-coded packet. The separate decoding has higher complexity than the direct decoding since two packets are decoded individually. In this paper, we compare the BER performance of the separate decoding and direct decoding in the SM-based PNC with CC.

II. SYSTEM MODEL

We consider the TWRN consisting of two source nodes with N_S antennas and a single relay node with N_R antennas. The packet transmission consists of two phases: multiple access (MA) and broadcast (BC) phases.

A. Multiple Access Phase

Fig. 1 shows the transmission procedure of two source nodes and the reception procedure of a single relay node in MA phase. Let \mathbf{b}_1 and \mathbf{b}_2 be the binary message sequences generated by the first source node (S_1) and the second source node (S_2), respectively. We assume that \mathbf{b}_1 and \mathbf{b}_2 have the same length of L each other, i.e., $\mathbf{b}_1 = \{b_{1,1}, b_{1,2}, \dots, b_{1,L}\}$ and $\mathbf{b}_2 = \{b_{2,1}, b_{2,2}, \dots, b_{2,L}\}$. Let \mathbf{u} and \mathbf{v} be the coded sequences which are encoded by a convolutional encoder, \mathcal{C} , with code rate $r = 1/N$ at S_1 and S_2 , respectively. In other words, $\mathbf{u} = \mathcal{C}(\mathbf{b}_1)$ and $\mathbf{v} = \mathcal{C}(\mathbf{b}_2)$ are generated by \mathcal{C} and they have the length of LN , i.e., $\mathbf{u} = \{u_1, u_2, \dots, u_{LN}\}$ and $\mathbf{v} = \{v_1, v_2, \dots, v_{LN}\}$. Let \mathbf{c} and \mathbf{d} be the sequence of modulated symbols at S_1 and S_2 , then they are expressed by $\mathbf{c} = \{\mathbf{c}_1, \dots, \mathbf{c}_{LN/N_b}\}$ and $\mathbf{d} = \{\mathbf{d}_1, \dots, \mathbf{d}_{LN/N_b}\}$ where N_b is the number of bits per channel (shown in (2) in detail). The i th of element of \mathbf{c} denotes the modulated symbol vector transmitted by S_1 at the i th symbol time and it is consisted of

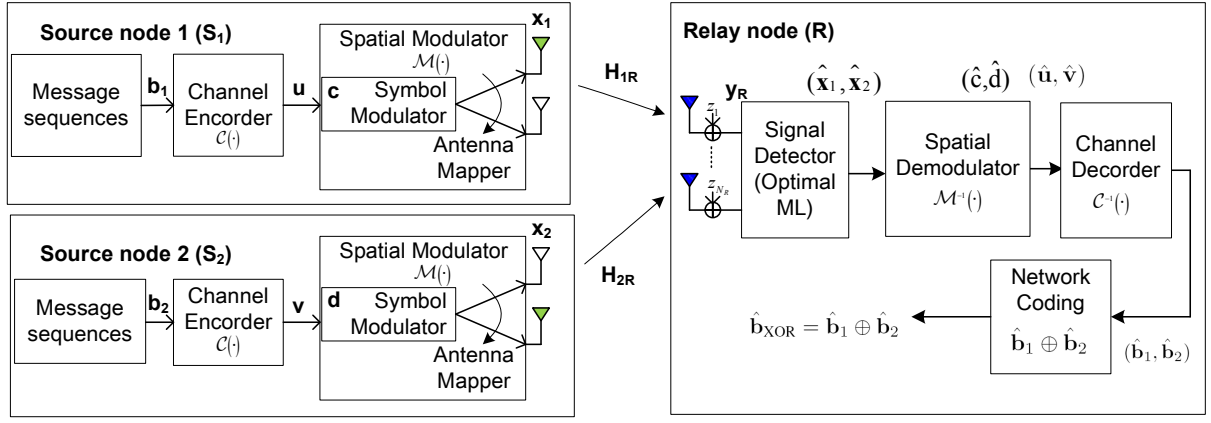

Fig. 1. System model of spatial modulation-based physical-layer network coding technique with separate decoding in multiple access phase

the number of N_b coded bits. Thus, $\mathbf{c}_i = \{c_{i,1} \cdots c_{i,N_b}\}$ and $\mathbf{d}_i = \{d_{i,1} \cdots d_{i,N_b}\}$ are obtained.

When a spatial modulator (SM), \mathcal{M} , is performed at the i th symbol time, we can obtain \mathbf{x}_1^i and \mathbf{x}_2^i as the modulated symbol vectors by S_1 and S_2 at the i th symbol time. To focus on a specific symbol time, we ignore the notation of the symbol time i and let \mathbf{x}_1 and \mathbf{x}_2 be the the modulated symbol vector instead of \mathbf{x}_1^i and \mathbf{x}_2^i . Thus, \mathbf{x}_1 and \mathbf{x}_2 are obtained from $\mathcal{M}(c_1, \cdots, c_{N_b})$ and $\mathcal{M}(d_1, \cdots, d_{N_b})$.

The SM is consisted of symbol modulator and antenna mapper. A single antenna is activated among N_s antennas by antenna mapper at each source node. Accordingly, the i th antenna is mapped to the i th symbol out of $\log_2 N_s$ symbols by antenna mapping procedure of the SM ($1 \leq i \leq N_s$). For example, if the number of antennas at each source node is equal to 2, i.e., $N_s = 2$, symbols using BPSK modulation can be transmitted. The first antenna transmits the symbol of '+1' while the second antenna transmits the symbol of '-1'. \mathbf{x}_k , $k \in \{1, 2\}$, is given by

$$\mathbf{x}_k \in \left\{ \begin{bmatrix} +1 \\ 0 \end{bmatrix}, \begin{bmatrix} -1 \\ 0 \end{bmatrix}, \begin{bmatrix} 0 \\ +1 \end{bmatrix}, \begin{bmatrix} 0 \\ -1 \end{bmatrix} \right\}. \quad (1)$$

Thus, the number of bits per channel use, N_b , is expressed as follows:

$$N_b = \lfloor \log_2 \binom{N_s}{1} \rfloor + \log_2 |\mathbb{A}|, \quad (2)$$

where \mathbb{A} denotes the symbol modulation alphabet, i.e., $\mathbb{A} = \{-1, +1\}$ for the BPSK modulation. The first term means the number of bits to be transmitted by antenna mapper while the second term means that of bits to be transmitted by symbol modulator.

Each source node simultaneously transmits $\mathbf{x}_k = \{x_{k,1}, \cdots, x_{k,b}, \cdots, x_{k, \log_2 |\mathbb{A}|}\}$, $\mathbf{x}_1 \in \mathbb{C}^{N_s \times 1}$ at S_1 and $\mathbf{x}_2 \in \mathbb{C}^{N_s \times 1}$ at S_2 . Then, the received symbol vector at the relay node, R , is expressed as follows:

$$\mathbf{y}_R = \mathbf{H}_{1R}\mathbf{x}_1 + \mathbf{H}_{2R}\mathbf{x}_2 + \mathbf{z}_R, \quad (3)$$

where $\mathbf{y}_R \in \mathbb{C}^{N_R \times 1}$, $\mathbf{H}_{1R} \in \mathbb{C}^{N_R \times N_s}$, $\mathbf{H}_{2R} \in \mathbb{C}^{N_R \times N_s}$, and $\mathbf{z}_R \in \mathbb{C}^{N_R \times 1}$ denote the received symbol vector at R , the wireless channel matrix from S_1 to R , the wireless channel

matrix from S_2 to R , and the additive Gaussian noise vector at R , i.e., $\mathbf{z}_R \sim \mathcal{CN}(\mathbf{0}, N_0\mathbf{I})$, respectively.

In the uncoded system, the relay node tries to detect the symbol vectors \mathbf{x}_k ($k = 1, 2$) received from S_k . The maximum-likelihood detector (MLD) is adopted at R . Let Ω be the set of all possible symbol pairs of $(\mathbf{x}_1, \mathbf{x}_2)$, then the estimate on the transmit symbol vectors is given by

$$(\hat{\mathbf{x}}_1, \hat{\mathbf{x}}_2)_{\text{ML}} = \arg \min_{(\mathbf{x}_1, \mathbf{x}_2) \in \Omega} \|\mathbf{y}_R - \mathbf{H}_{1R}\mathbf{x}_1 - \mathbf{H}_{2R}\mathbf{x}_2\|^2. \quad (4)$$

In the coded system, however, the detector tries to calculate the log-likelihood ratio (LLR) of the coded bits, i.e., \mathbf{u} , \mathbf{v} . There exist two types of decoding methods: a separate decoding and a direct decoding [1]. In case of separate decoding, the LLR for each coded bits from two sources is computed, and then the channel decoder performs decoding by using each LLR values for decoding the individual packet from the sources. Thus, the decoder performs decoding procedure twice and the network coding operation (XOR) is performed by using the two decoded bits, i.e., $\hat{\mathbf{b}}_1, \hat{\mathbf{b}}_2$. Thus, the output of the separate decoder is given by $\hat{\mathbf{b}}_{\text{XOR,sep}} = \hat{\mathbf{b}}_1 \oplus \hat{\mathbf{b}}_2$. On the other hand, in case of direct decoding, the LLR for the network coded version (XOR) of coded bits is directly computed at the detector, and then the decoder performs decoding by using the computed LLR values. Then, the output of the decoder becomes the estimator of the network coded packet from two source nodes and it is given by $\hat{\mathbf{b}}_{\text{XOR,dir}} = \hat{\mathbf{b}}_1 \oplus \hat{\mathbf{b}}_2$.

In summary, the separate decoding separately decodes the individual bits, i.e., $\hat{\mathbf{b}}_1, \hat{\mathbf{b}}_2$, and then the network coding operation (XOR) is performed for $\hat{\mathbf{b}}_1$ and $\hat{\mathbf{b}}_2$. In contrast, the direct decoding directly decodes the network coded packet, $\hat{\mathbf{b}}_1 \oplus \hat{\mathbf{b}}_2$, and thus it produces the network coded bits, i.e., $\hat{\mathbf{b}}_1 \oplus \hat{\mathbf{b}}_2$.

B. Broadcast Phase

Let \mathbf{b}_{XOR} be the network-coded bits at R in the BC phase, and it is sent to S_1 and S_2 in the BC phase. It is also modulated with encoder and spatial modulator as the same function of the MA phase.

Since the BER performance of the SM-based PNC technique depends on the BER performances in BC phases, we

III. SIMULATION RESULTS

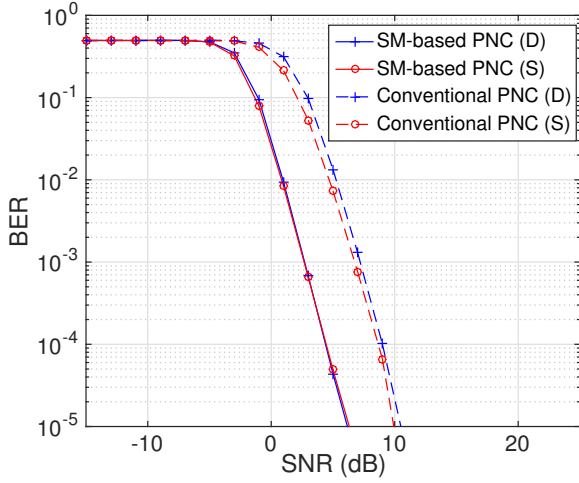

Fig. 2. BER performance of the proposed SM-based PNC and the conventional PNC techniques with direct decoding (D) or separate decoding (S) algorithm when $N_S = 4$, $N_R = 4$, and $N_b = 5$.

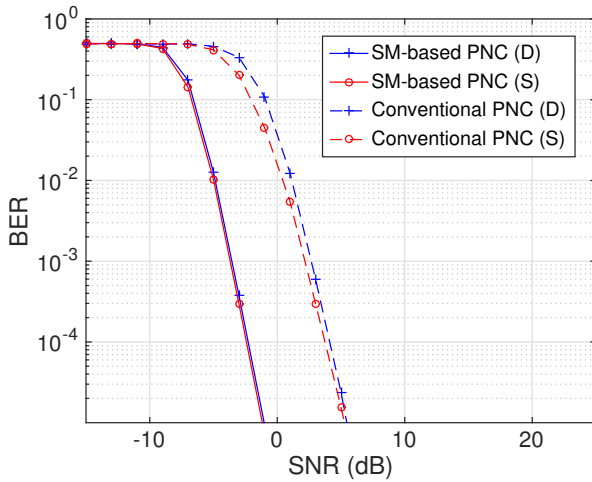

Fig. 3. BER performance of the proposed SM-based PNC and the conventional PNC techniques with direct decoding (D) or separate decoding (S) algorithm when $N_S = 8$, $N_R = 8$, and $N_b = 5$.

focus on the BER performance at S_1 and S_2 in the BC phase. Let $P_{b,1}^{BC}$ and $P_{b,2}^{BC}$ denote the bit-error probability at S_1 and S_2 in the BC phase, respectively. They are expressed as follows:

$$P_{b,1}^{BC} = \Pr\{\hat{\mathbf{b}}_{\text{XOR},1} \neq \mathbf{b}_{\text{XOR}}\}, \quad (5)$$

$$P_{b,2}^{BC} = \Pr\{\hat{\mathbf{b}}_{\text{XOR},2} \neq \mathbf{b}_{\text{XOR}}\}, \quad (6)$$

where $\hat{\mathbf{b}}_{\text{XOR},1}$ and $\hat{\mathbf{b}}_{\text{XOR},2}$ denote the estimate on the network-coded bits at S_1 and S_2 , respectively. \mathbf{b}_{XOR} may be different from $\mathbf{b}_1 \oplus \mathbf{b}_2$ if there exists bit error in the MA phase.

Using the estimate on the network-coded bits, $\hat{\mathbf{b}}_{\text{XOR}}$, S_1 performs the network decoding with the bit-wise XOR operation in order to obtain the information bits of S_2 . S_1 obtains the information bits of S_2 by performing the bit-wise XOR operation between $\hat{\mathbf{b}}_{\text{XOR}}$ and \mathbf{b}_1 , i.e., $\hat{\mathbf{b}}_2 = \hat{\mathbf{b}}_{\text{XOR}} \oplus \mathbf{b}_1$. Similarly, S_2 obtains the information bits of S_1 via the bit-wise XOR operation between $\hat{\mathbf{b}}_{\text{XOR}}$ and \mathbf{b}_2 , i.e., $\hat{\mathbf{b}}_1 = \hat{\mathbf{b}}_{\text{XOR}} \oplus \mathbf{b}_2$. Therefore, each source node exploits its own information bits, which are sent in the MA phase, for obtaining the information bits of the other source node from the network-coded bits.

For the CC, the constraint length is set to 7 and the code rate is set to $1/2$. As a decoding algorithm, Viterbi algorithm is adopted. We compare the performance of the SM-based PNC technique with that of the conventional PNC technique having the same number of RF chains. For achieving that $N_b = 5$, the conventional PNC technique adopts 32QAM modulation. In contrast, in figure 2, the SM-based PNC technique allocates 2 bits in antenna domain with 4 transmit antennas and 3 bits in symbol constellation domain, i.e., 8PSK modulation, respectively. In figure 3, for achieving that $N_b = 5$, the proposed SM-based PNC technique allocates 3 bits in antenna domain with the 8 transmit antennas and 2 bits in symbol constellation domain, i.e., QPSK modulation, respectively. From figures 2 and 3, the SM-based PNC technique results in much better BER performance than the conventional PNC technique. Note that, in figures 2 and 3, ‘‘D’’ and ‘‘S’’ stand for ‘‘direct decoding’’ and ‘‘separate decoding’’, respectively. In SM-based PNC technique, the BER performances of the separate decoding and the direct decoding are almost the same although the separate decoding requires 2 times more decoding complex than the direct decoding.

IV. CONCLUSIONS

In this paper, we considered a physical-layer network coding technique for two-way relay network, which exploits the spatial modulation at both source nodes and the relay node. The relay node tries to decode the network-coded packet of the received packets from two source nodes. In particular, we also consider the convolutional code (CC) as a channel coding technique, while many related studies did not consider the channel coding techniques. We considered two difference decoding algorithms for the SM-based PNC technique: separate decoding and direct decoding. Simulation results show that the direct decoding yields low complexity than the separate decoding, while achieving almost the same performance as the separate decoding.

ACKNOWLEDGEMENT

This work was supported by the Basic Science Research Program through the National Research Foundation of Korea (NRF) funded by the Ministry of Science, ICT & Future Planning (MSIP) (NRF-2016R1A2B4014834).

REFERENCES

- [1] B. C. Jung, ‘‘A practical physical-layer network coding for fading channels,’’ *International Journal of KIMICS*, Vol. 8, No. 6, pp. 655–659, Dec. 2010.
- [2] D. To and J. Choi, ‘‘Convolutional codes in two-way relay networks with physical-layer network coding,’’ *IEEE Trans. Wireless Commun.*, Vol. 9, No. 9, pp. 2724–2729, Jul. 2010.
- [3] Q. Yang and S. C. Liew., ‘‘Optimal decoding of convolutional-coded physical-layer network coding,’’ in Proc. of *IEEE WCNC*, Apr. 2014.
- [4] S. H. Kim, B. C. Jung, and D. K. Sung, ‘‘Transmit power optimization for two-way relay channels with physical-layer network coding,’’ *IEEE Commun. Lett.*, Vol. 19, No. 2, pp. 151–154, Feb. 2015.
- [5] X. Xie, Z. Zhao, M. Peng, and W. Wang, ‘‘Spatial modulation in two-way network coded channel: Performance and mapping optimization,’’ in Proc. of *IEEE PIMRC*, Sep. 2012.
- [6] M. Wen, X. Cheng, H. V. Poor, and B. Jiao, ‘‘Use of SSK modulation in two-way amplify-and-forward relaying,’’ *IEEE Trans. Veh. Technol.*, Vol. 63, No. 3, pp. 1498–1504, Mar. 2014.
- [7] K. G. Unnikrishnan and S. Rajan, ‘‘Space-time coded spatial modulated physical-layer network coding for two-way relaying,’’ *IEEE Trans. Wireless Commun.*, Vol. 14, No. 1, pp. 331–342, Jan. 2015.